

# THE FUTURE (AND THE PRESENT) OF MOTOR VEHICLE PROPULSION SYSTEMS \*

*Ivan A. BLAGOJEVIĆ, Saša R. MITIĆ, Dragan D. STAMENKOVIĆ, Vladimir M. POPOVIĆ*

<sup>1</sup>University of Belgrade, Faculty of Mechanical Engineering, Serbia

*Limited reserves of oil and the increasing environmental effect of its usage as a motor fuel represent global issue related to the constantly increasing number of motor vehicles. Therefore, the reduction of the fossil fuel consumed and the emission produced in internal combustion engines is the primary goal of the development of motor vehicle propulsion systems. In that sense, the present and the future of motor vehicles relies on hybrid drive systems, electric drive systems and drive systems which use hydrogen as a fuel (either by its combustion or by production of electric energy with the help of fuel cells). In this paper, the authors have presented the above-mentioned motor vehicle propulsion systems by explaining their function and design, their basic elements and their functions. Authors have also analyzed advantages and disadvantages of the mentioned propulsion systems in comparison to conventional internal combustion engine (ICE) based systems, both technically and environmentally speaking, but also in relation to available infrastructure and energy resources.*

Key words: *hybrid vehicles, electric vehicles, fuel cells, hydrogen, fuel consumption, exhaust emission, IC engine*

Paper previously published in

**Thermal Science**, Volume 23, Issue Suppl. 5, Pages: 1727-1743 (2019)

## 1. Introduction

Nowadays, oil, coal and natural gas are three major energy sources. The share of sources such as nuclear energy, geothermal springs and wind is significantly smaller, whereas so-called alternative fuels and innovative technologies take only a small part. Unfortunately, oil is not a renewable source of energy. According to the forecast [1], drastic changes will happen in year 2040 (Fig. 1). By that time, the production of crude oil will increase, but it will be followed by a sudden decrease; thus, it is expected that in 2100 major sources of energy will be coal, renewable liquid and gaseous biofuels, solar energy, wind energy, as well as hydropower and nuclear energy. Also, there is the problem of unequal distribution of oil as a natural resource - for many countries, it is an import energy source whose price varies.

Estimates from 2014 point to the fact that 98% of motor vehicles on the planet use IC engines running on hydrocarbon-based fuels, whereby the above-mentioned percentage will not significantly change in the following ten to fifteen years. According to the statistical data [2], the number of motor vehicles in the world in 2014 was over 1.23 billion (Fig. 2). The number of vehicles in 1970 was approximately five times smaller and in only 16 years (by 1986) the number of vehicles has doubled. In 2009, the number of motor vehicles on the planet already exceeded 1 billion. In only five years (from 2009 to 2014), the number of vehicles increased by more than 200 million – more than 20%. It is estimated that, by the year of 2035, the number of vehicles on the planet will reach two billion [3]. Such a forecast is not encouraging at all, because of the fact that limited sources of energy are being used, primarily oil, which still represents the world leading energy source for the motor vehicles, and also because of the global pollution of our planet due to exhaust emission of IC engines.

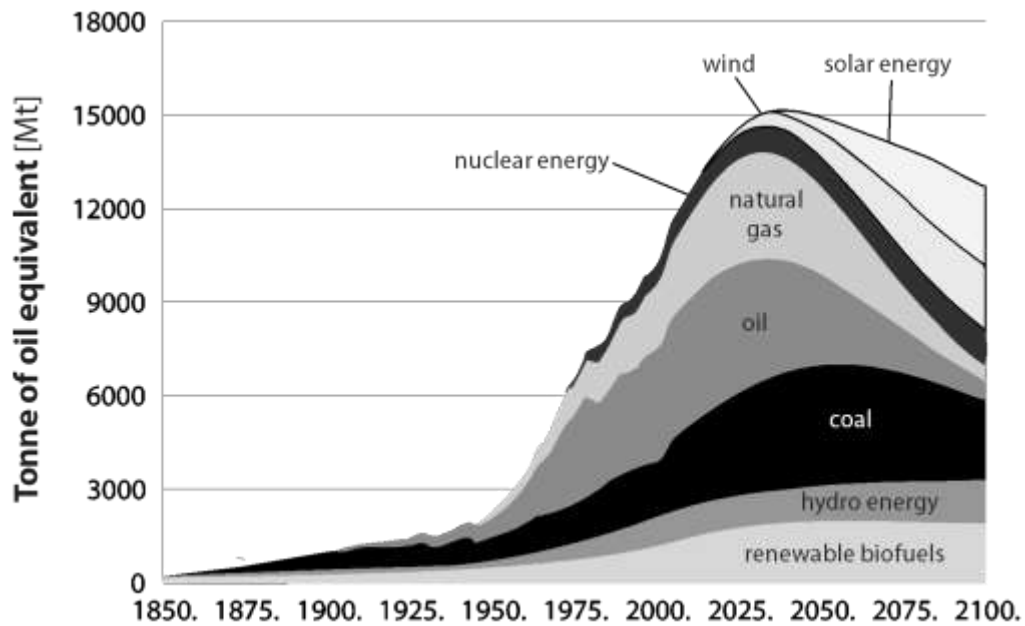
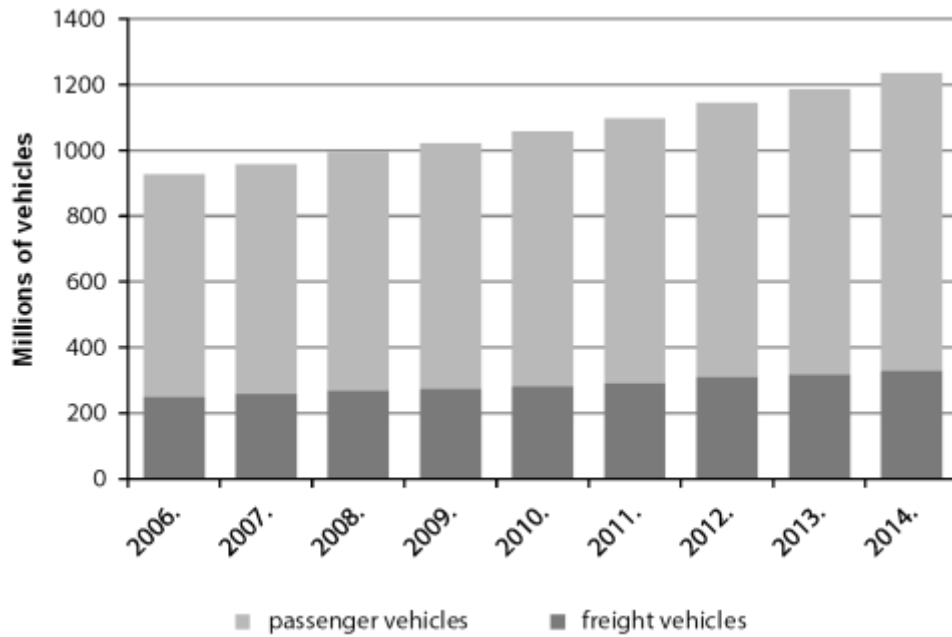

**Figure 1. Forecast of energy demand**

It should be emphasized that the research has shown that the increase in fuel consumption while driving is followed by the increase in harmful exhaust emission, but in different proportions for various emission components. For example, if the difference in fuel consumption caused by different driving techniques is 21%, the difference in emission can be 72% for hydrocarbons and 48% for nitrogen oxides [4]. The content of carbon dioxide in exhausts is proportionate to the fuel consumption. According to the data provided by the U. S. Environmental Protection Agency, transportation represented 27% of total U.S. GHG emissions in 2015, 83% of which is caused on-road vehicles [5]. Each litre of petrol combusted in the vehicle engine produces 2.35 kg of CO<sub>2</sub> on average, whereas each combusted litre of diesel releases in the atmosphere 2.69 kg of CO<sub>2</sub> on average [6]. Average passenger vehicle emits 4.7 tons of carbon dioxide over one year [6]. This clearly shows that fuel-efficient driving not only saves fuel, but also contributes to the environment protection. Carbon dioxide is present in the air as a natural ingredient and it is not considered a pollutant in terms of exhaust emission of motor vehicles. However, it is considered one of major causes of climate changes due to “greenhouse effect”. Atmospheric CO<sub>2</sub> levels rose to 395 parts per million in 2012. Making the second highest jump since 1959, when the measurements of atmospheric carbon dioxide levels began [7]. The direct relationship between exhaust emission and human health points to the significance of the reduction of the emission produced by fuel combustion.

Limited sources of oil and increased exhaust emission of motor vehicles represent the global challenge for the researchers. The problems are solved by applying new solutions on existing IC engines, as well as by using alternative fuels such as liquefied petroleum gas, compressed natural gas or certain kinds of biofuels.

However, a special way to solve the above-mentioned problems is to develop and use modern solutions, such as hybrid vehicles, electric vehicles and vehicles running on hydrogen. This paper presents their propulsion systems.



**Figure 2. Total number of vehicles in the world**

## 2. Hybrid vehicles

### 2.1. The concept of the hybrid drive and its characteristics

A hybrid vehicle is each vehicle which converts two or more different types of energy into mechanical energy which is used to drive the vehicle [8]. The most common are hybrid electric vehicles (HEV) using the internal combustion engine (petrol or diesel based) and the electric motor [9]. The combination of IC engines and hydraulic or pneumatic drive systems is rarely used, as well as some other variants which will not be discussed here. A task of the hybrid vehicle is to combine good characteristics of both propulsion systems and to reduce their negative characteristics to a minimum.

Considering its power output, IC engine has a small weight and it occupies a relatively small space, tank refuelling is quick and drive range is rather high. However, IC engines do not have a high efficiency ratio and their exhaust emission cannot be ignored. Also, the working range of IC engines in real exploitation is not the range of minimum specific fuel consumption (low engine speed with higher loads) and the torque values are usually low at low engine speed (which is case when starting from the standstill, which is especially important for city driving) [10].

Unlike the IC engines, the maximum torque of the electric motor is already available when the vehicle is started, which is very important for starting the vehicle from the standstill. Besides, the electric motor has zero harmful exhaust emission and its high efficiency ratio does not depend on load. On the other hand, electric motor with the same power output weigh more than corresponding IC engines, while required batteries also increase the weight of the vehicle and occupy space that would be used for passengers or cargo. The battery charging process is significantly slower compared to refuelling the tank with fossil fuel. The drive range is rather limited compared to the vehicle driven by IC engines. Figure 3 shows torque curves for different drive units.

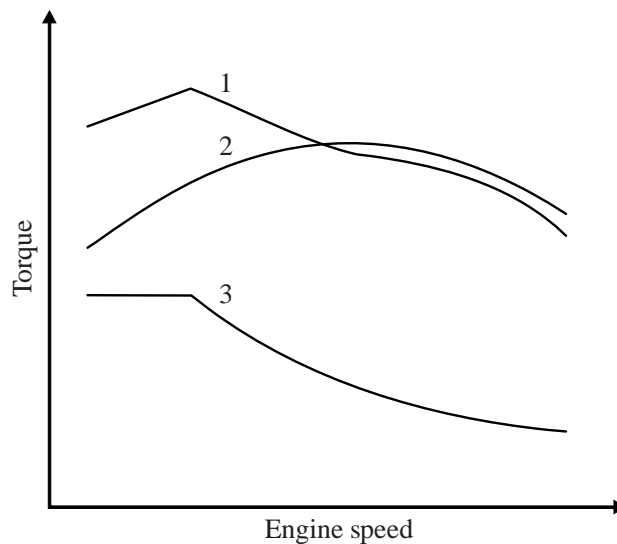

**Figure 3. Torque curves for different types of drive units:** 1 - hybrid drive; 2 – IC engine; 3 – electric motor

According to the above-mentioned advantages and disadvantages of electric motor and IC engine, as well as available torque values for different engine speed, it can be concluded that combining these two engines can lead to following benefits [11]:

- IC engine works only in the range of higher efficiency ratio, i.e. smaller specific fuel consumption;
- It is possible to use smaller displacement engines;
- When braking, a part of kinetic energy can be transformed into electric energy with the help of electric motor, which then works in generator mode;
- Due to higher efficiency ratio of IC engine, exhaust emission is reduced and, in some cases, power is provided only by the electric motor, which gives zero exhaust emission.

Although the hybrid vehicle was patented at the end of the 19<sup>th</sup> century, its real development started at the end of the 20<sup>th</sup> century because of the pollution and due to the increasing price of oil and its limited reserves.

## 2.2. The design of the hybrid drive

IC engine, electric motor and transmission are components of the hybrid drive which enables conversion and flow of different forms of energy. Depending on its design, configuration of the hybrid drive system can be series, parallel, series-parallel and configuration with planetary transfer gear [12,13].

### 2.2.1 Series configuration of the hybrid drive

In series hybrid drive, there is no mechanical connection between the IC engine and wheels. Wheels are driven only by the electric motor which can be powered by battery or the energy produced by the generator driven by the IC engine. The electric motor can also be used to produce the electric energy through regenerative braking and store it in the batteries. In that case, the energy of wheels is used to turn the rotor of the electric motor, which acts as a generator. Instead of converting kinetic energy into heat, one part is accumulated as electric energy. Figure 4 shows series configuration of the hybrid drive.

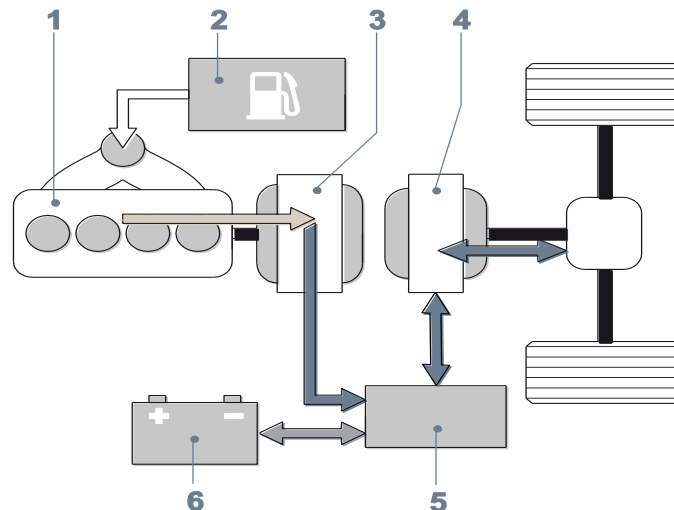

**Figure 4. Series configuration:** 1 - IC engine; 2 - fuel tank; 3 - generator; 4 - electric motor; 5 - pulse-controlled inverter; 6 - battery

Series configuration of the hybrid drive has a number of advantages. There is no mechanical connection between the IC engine and the wheels, so the engine operation can be optimized with the highest possible efficiency ratio; i.e. the lowest possible fuel consumption and exhaust emission. It can be achieved if the engine runs at consistent speed and appropriate load. The fact that there is no mechanical connection with the driving wheels gives a possibility of installing high-speed engines such as gas turbines. Also, the IC engine and the generator can be placed anywhere in the vehicle. It is also possible to use smaller displacement (and because of that lighter) engines, which additionally reduce the exhaust emission. The torque characteristic of electric motors does not require multi-speed transmission, which is also reflected on the weight of the vehicle. The above-mentioned configuration allows the use of two or more smaller electric motors, one for each driving wheel, so there is no need to use differential gear. Series configuration of the hybrid drive system is simple compared to other configurations.

Series hybrid drive systems perform well when the vehicle is used for city driving with frequent stop-and-go operation. With fully charged batteries, the vehicle uses only energy stored in batteries. Slow speed driving through the city can also be achieved in pure electric mode. For these vehicles, only a small amount of fuel is needed to move the vehicle from standstill. Some systems offer the possibility of charging the batteries via electric network (e.g. during the night), which additionally reduces the fuel consumption.

However, series configuration of the hybrid drive system has also its negative sides and the biggest one of all is multiple energy conversion and accompanying losses. The energy produced by the IC engine, where the first conversion from chemical/thermal energy into mechanical energy takes place, needs to convert two more time on its way to the driving wheels. In the generator, mechanical energy is first converted into electric energy, and then electric energy is converted into mechanical energy again on its way out of the electric motor, but with some losses. That is why the efficiency ratio of the generator and the electric motor is very important. Series hybrid drive requires batteries with greater capacity than the parallel hybrid drive systems, which considerably increases the weight. The presence of the generator also increases the weight of the vehicle, as well as the price. Series hybrid drive performs poorly when driving at high speeds (e.g. on motorways) or on longer hills because then they use electric energy produced only by the generator driven by the IC engine, which is not good because of the above-mentioned energy conversion and losses arisen.

Series configuration of the hybrid drive system are usually in heavy commercial vehicles and buses since they have more available space, as well as bigger and heavier batteries and generators.

### 2.2.2 Parallel configuration of the hybrid drive system

The major difference between the series and parallel configuration of the hybrid drive is that the parallel drive doesn't need energy conversion between the ICE and electric motor, since it can use the energy

from both sources at the same time. Both motors have mechanical connections with the driven wheels. In most concepts, the primary source of power is the IC engine, while the electric motor provides assistance in certain driving modes. There are also concepts which enable the vehicle to be propelled only by the electric motor. The electric motor can take over the role of the generator during regenerative braking. If, when working in the optimum mode, the IC engine delivers more power than it is needed to overcome resistance forces (which suits moderate driving modes), the surplus of power is used to recharge the battery.

Transfer gear can be a conventional gear or a planetary gear, chain or belt drive. Depending on the number of clutches, types of elements for power distribution, as well as the number of driving axles, there are several different variants of parallel configuration of the hybrid drive system.

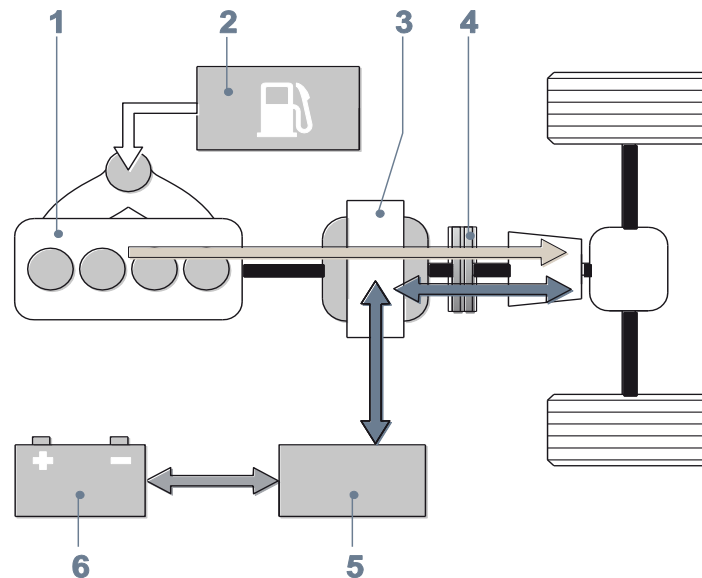

**Figure 5. Parallel configuration with one clutch:** 1 - IC engine; 2 - fuel tank; 3 - electric motor/generator; 4 - clutch; 5 - pulse-controlled inverter; 6 - battery

Figure 5 shows the variant of parallel configuration with one clutch (and one shaft). The electric motor is directly connected to the internal combustion engine. Unlike the series configuration, the IC engine speed cannot be adjusted regardless of electric motor speed. When the vehicle is slowing down, the IC engine cannot be disconnected from the electric motor, which has a negative impact on the regenerative braking effect. Pure electric driving mode is not possible for this variant, so the role of the electric motor is only to assist the IC engine.

The advanced variant of the parallel configuration has been achieved with two clutches (and one shaft) - additional clutch is added between the IC engine and the electric motor which enables switching the IC engine on and off when necessary, i.e. drive only via the electric motor. The IC engine can also be switched off when the vehicle is slowing down which increases the potential of regenerative braking. In order to have a shorter assembly, there is a solution with double clutch or two independent shafts – one for the IC engine and the other for the electric motor.

There is another parallel configuration of the hybrid drive - it enables one driven axle to be driven by the IC engine, and the other one by the electric motor. This configuration has been classified as parallel because the power outputs of the IC engine and the electric motor are combined. Apart from the all-wheel drive, it is also possible to distribute the torque per wheel in wide ranges. In order to provide constant all-wheel drive, there must be another generator driven by the existing IC engine. In that way, batteries can be additionally charged (not just by regenerative braking).

The advantages of the parallel configuration of the hybrid drive system are reflected in the fact that the vehicle is driven using both engines, without the conversion of energy, i.e. with smaller losses than in the series configuration. The design is more compact compared to the series configuration if there is no generator and because of the smaller electric motor. Therefore, this configuration can be used in smaller vehicles. The major disadvantage of this configuration is the fact that the IC engine and the electric motor are mechanically connected to the transmission and therefore the operation of the IC

engine cannot be optimized ideally. This type of systems requires complex management and complex transmission.

The parallel configuration of the hybrid drive system is relatively easy to implement by upgrading the existing conventional vehicle propulsion system.

### 2.2.3 Series-parallel configuration of the hybrid drive system

The series hybrid drive system has been extended into the series-parallel hybrid drive system (Fig. 6) by establishing mechanical connection via the clutch between two electric motors, one of which operates only as a generator. The series-parallel hybrid drive system can use advantages of the series hybrid drive system at low speeds and avoid disadvantages at higher speeds when the clutch is switched on and when the series-parallel hybrid drive system operates like the parallel hybrid drive system.

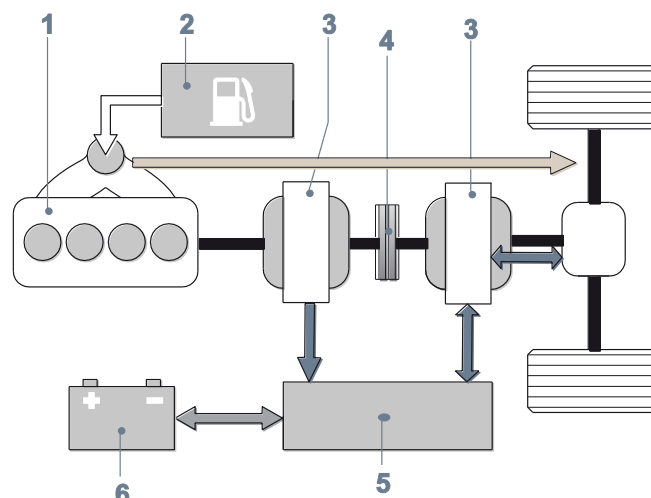

**Figure 6. Series-parallel configuration:** 1 - IC engine; 2 - fuel tank; 3 - electric motor/generator; 4 - clutch; 5 - pulse-controlled inverter; 6 – battery

Since the double conversion of energy is limited to the low range of speeds and power outputs, the series-parallel hybrid drive systems need smaller electric motors compared to the ones in the series hybrid drive systems. The series-parallel configuration is not as compact as the series configuration and, in comparison with the parallel configuration, it requires an additional generator.

### 2.2.4 The configuration of the hybrid drive with the planetary transfer gear

The configuration with the planetary transfer gear combines the characteristics of the parallel and series hybrid drive systems – it is most similar to the series-parallel configuration, so some sources in the literature refer to these two configurations as one. A part of the power of the IC engine is converted, with the help of the generator, into the electric energy and the rest of it, together with the power produced by the electric motor, is used to drive the vehicle. The configuration with the planetary transfer gear is always a complete hybrid drive system (see Tab. 1) because it enables all necessary functions (start/stop function, regenerative braking, hybrid drive and only-electric drive).

The design is shown in Fig. 7. The planetary transfer gear connects the IC engine, the generator and the electric motor by using its three elements (sun gear, planet carrier and ring gear). That the IC engine speed can be adjusted within optimum limits, regardless of the vehicle speed.

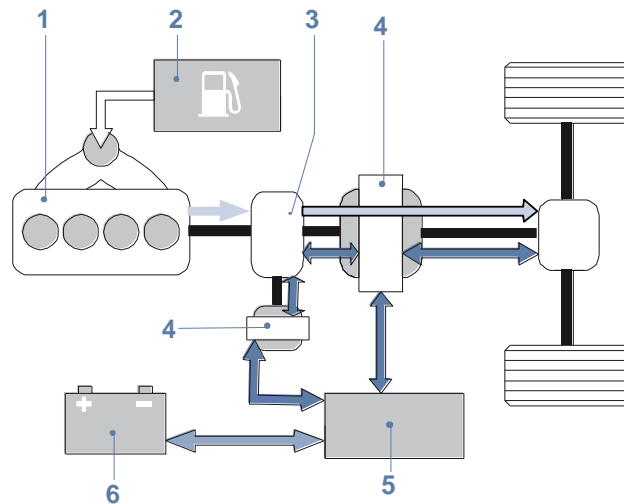

**Figure 7. Configuration with planetary transfer gear:** 1 - IC engine; 2 - fuel tank; 3 - planetary transfer gear; 4 - electric motor/generator; 5 - pulse-controlled inverter; 6 - battery

A part of the power of the IC engine is mechanically transmitted, via the planetary transfer gear, to the driven wheels. The rest of the power is transmitted to the driven wheels electrically, with double conversion of energy. Similarly to the series hybrid drive system, pure electric transmission can be used if the vehicle needs small amount of power. However, random switching between mechanical and electric drive systems is not possible. In this way, the hybrid drive system with the planetary transfer gear can significantly save fuel at low and medium speeds. Further fuel savings at high speeds are not possible.

The advantages of this configuration are as follows: the operation of the IC engine is controlled so that its performance is optimum for the given conditions; the IC engine can drive the wheels and recharge the battery at the same time; with the help of both drive units, the vehicle can achieve higher acceleration; in city conditions, the vehicle can function as a vehicle with the series hybrid drive system and minimum air pollution or as a pure electric vehicle with zero emission. The complex kinematics of the transmission mechanism (transfer gear), a great number of components and the high weight, as well as a very complex management algorithm are disadvantages of this configuration.

### 2.3. Classification of hybrid vehicles by their functions and driving modes (levels of hybridization)

Beside the classification referring to the design of the hybrid drive, there is another important classification of hybrid vehicles – by the level (degree) of hybridization or functions which the hybrid electric vehicle can perform. The functions and driving modes are as follows:

**Start/stop function** – It switches the IC engine off when the vehicle is not moving (a roadblock, red traffic light etc.). The electric motor starts rotating the crankshaft of the IC engine at optimum speed. The engine start is almost instant. The source of energy for the electric motor is the battery which can be recharged by regenerative braking or by the electric motor operating as the generator driven by the IC engine. The electric motor can also keep the vehicle accessories working while the IC engine is at standstill.

**Regenerative braking mode** – When the vehicle is slowing down, a part of kinetic energy is converted into electric energy by the electric motor operating as the generator driven by the wheels. Conventional (hydraulic) braking system is still present in order to enable necessary performance, but the amount of energy which is converted into heat, by mechanical friction is smaller.

**Hybrid driving mode** – In hybrid mode, both the IC engine and the electric motor provide the necessary torque. It should be emphasized that, in this mode, a part of the torque of the IC engine can be, apart from propelling the vehicle, used to start the generator and produce the electric energy to feed the electric motor, i.e. to charge the battery.

**Pure electric driving mode** – In this driving mode, the vehicle moves only using electric energy without the harmful exhaust emission and with reduced noise level.



Recharging batteries at charging stations – It is possible to connect some hybrid vehicles, via appropriate charging inlet, to the electric network in order to recharge their batteries. Such vehicles are called plug-in hybrid electric vehicles (PHEV).

In accordance with the functions and modes supported by the hybrid electric vehicle, they have been classified by the level of hybridization (Tab. 1).

**Table 1. The levels of hybridization according to the vehicle functions/modes**

<i>Functions/modes</i>	<i>Levels of hybridization</i>			
	<i>Micro hybrid</i>	<i>Mild hybrid</i>	<i>Full hybrid</i>	<i>Plug-in hybrid</i>
Start/stop	•	•	•	•
Regenerative braking	•	•	•	•
Hybrid mode		•	•	•
Electric mode			•	•
Recharging at charging stations				•

According to some studies, micro hybrid can save between 4% and 5% of fuel, mild hybrid between 10% and 15% and full hybrid between 20% and 30%, while, naturally, plug-in hybrid saves the largest amount of fuel (between 50% and 70%), but without the amount of consumed electric energy taken into account [14].

### 3. Electric vehicles

Electric vehicles are motor vehicles driven by the electric motor fed from the electrochemical source of electric energy. Electric vehicles do not pollute the environment and they can be called Zero Emission Vehicles (ZEV). This chapter will focus only on electric vehicles with their own batteries, whereas the vehicles with the system for the production of electric energy with the help of fuel cells will be analyzed in the following section that focuses on hydrogen as a fuel.

Electric vehicles have a number of advantages over the vehicles with the IC engines: zero exhaust emission, significantly lower noise level, minimum operating vibrations, smooth start at low temperatures, instant availability of maximum torque, high energy efficiency ratio, low maintenance costs, low running costs, extremely good drive characteristics of the electric motor with certain allowed overloads, no dependence on oil products and possibility of using domestic energy resources. However, electric propulsion systems have certain disadvantages compared to conventional vehicles: smaller driving range and speed (in most cases), higher vehicle weight and less free space because of the battery, slow battery recharging and the need for battery-charging network [15,16].

#### 3.1. Components of electric propulsion system and its design

Generally speaking, basic components of the electric propulsion system are: electric motor, batteries with the recharging system, electronic control unit and the transmission system. These basic components with accompanying elements are functionally interconnected in order to form a specific design of the electric vehicle which, in a general sense, looks like the one presented in Fig. 8 [17]. The greatest deviations from the design presented in general sense can be in terms of the existence of the transmission and its method of implementation, which will be explained in further text in more details.

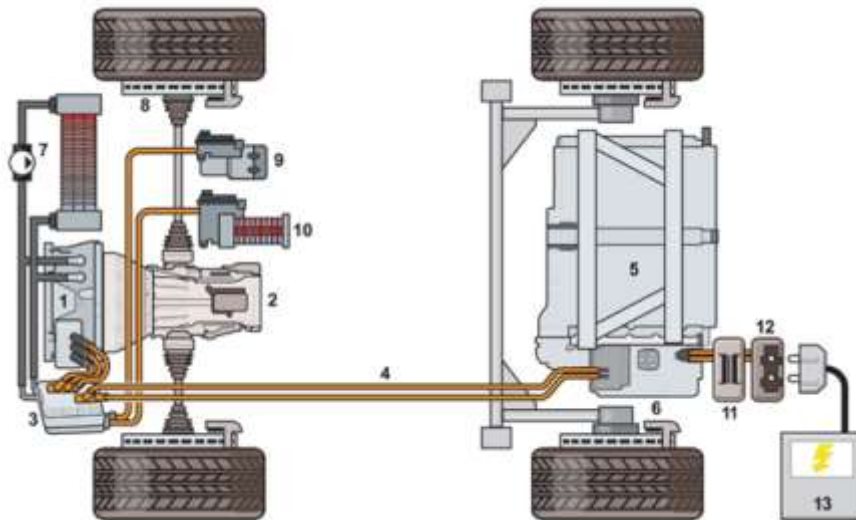

**Figure 8. Design of electric drive system with components:** 1 - electric motor (generator); 2 - transmission system; 3 - electronic control unit for electric motor management (controller); 4 – high-voltage lines; 5 – high-voltage battery; 6 - inverter with electronic control unit for battery operation and charging; 7 - cooling system; 8 - brake system (including regenerative braking); 9 - high-voltage AC compressor; 10 - heating system; 11 - battery charger; 12 - charging inlet; 13 - external source of electric energy for battery recharging

### 3.1.1 *Electric motor*

There is a great variety of motors in electric vehicles, but the ones used most frequently are three-phase AC motors – induction asynchronous motors and permanent-magnet synchronous motors – as well as DC motors with brushes or without brushes (permanent magnet).

The selection of the electric motor is a very important step and it depends on preferred levels of performance, vehicle concept and characteristics of the battery. Permanent-magnet motors are becoming increasingly popular because of the high current density, i.e. because of the favourable power characteristics and compact design, even though their management algorithms are complicated. On the other hand, DC motors are easier to install, more reasonably-priced and more suitable for short-term accelerations at lower speeds. Disadvantages are: the increase in operating temperature, possible uncontrolled increase in engine speed and poor characteristics in generator mode. Because of the disadvantages mentioned, AC motors are the first choice. The characteristic of all electric motors is significantly higher efficiency (sometimes over 95%) compared to IC engines [18]. It is already mentioned that the torque curve of electric motors is more suitable for use in vehicles than the torque curve of conventional IC engines, since it is highest at the lowest engine speeds, which is of great significance when starting the vehicle from the standstill, as well as for overcoming hills.

### 3.1.2 *Transmission system and design of the drive system*

There are several solutions for the design of the electric vehicle propulsion system [19]: from solutions which strongly resembles the conventional vehicle with the IC engine, which means that there is an electric motor connected to the multi-speed gearbox with a clutch, to solutions where the wheel has its own drive unit which enables its independent propulsion, where power transmission elements are not necessary. The need for a multi-speed gearbox or just a fixed-ratio reduction gear depends on the purpose of the vehicle and preferred vehicle performance and on the characteristics of the electric motor itself. In all cases with one electric motor, it is necessary to have a differential gear and drive shafts, whereas, in case of one electric motor per wheel (on one or two axles), these elements are redundant.

Figure 9 shows possible designs of electric propulsion system with suitable transmission systems. Case a) shows the variant of the electric vehicle whose transmission system does not essentially differ from the transmission system of conventional vehicles with the IC engines. Case b) shows the variant where there is no clutch and the gearbox, but only one additional gear with fixed ratio (reduction

gear). The advantage of this transmission system is reduction in vehicle weight, which allows implementation of a more complicated electric motor management system for providing necessary torque. Case c) does not essentially differ from the case b), but in this variant, motor, additional gear and differential gear are within one assembly. Case d) is the variant with two motors. In this configuration, the difference in engine speed of the left and right wheel is managed by electric motor management system. In order to avoid mechanical transmission and reduce losses, electric motors can be installed in wheels. Case e) shows the concept where there is an additional reduction gear next to the motor in the wheel. Due to the high speed of the electric motor, its compact design and the possibility of input-output alignment, planetary gears are always applied in cases like these. The last case f) also shows the variant with the motor in the wheel, but without any mechanical transmission. In this case, different electric motors are used with significantly more complex algorithms for their management. The same principle is applicable on wheels of the other axle, consisting the all-wheel drive system.

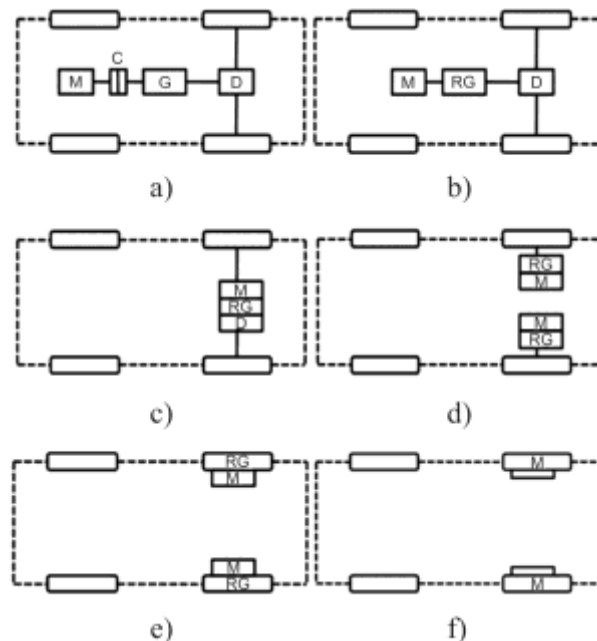

**Figure 9. Possible designs of electric propulsion system with an appropriate transmission: M – electric motor; C – clutch; G – gearbox; RG – reduction gear; D – differential gear**

#### 4. Hydrogen propelled vehicles

Nowadays, hydrogen is one of the most interesting solutions for propelling the motor vehicles even though, globally speaking, we are far from using it massively. Many car manufacturers have presented their prototypes and models driven by hydrogen with the aim to emphasize that there is a potential in it.

The greatest advantage of hydrogen is the fact that it does not pollute the environment. It does not emit carbon in any form, which also applies to carbon dioxide, nitrogen oxides or particulates. The major disadvantage is the high price of the vehicle. Also, the great problem is the infrastructure itself – starting from the hydrogen factories to hydrogen filling stations. The production of hydrogen is estimated to be at least five times more expensive than the production of petrol. The fact that car manufacturers are interested in this technology and its improvement is encouraging, so it is rightfully expected that in the future the process of hydrogen production will be significantly cheaper. Another disadvantage of the hydrogen usage is that it is separated through the process of electrolysis that needs electricity, which can be largely produced by environment-unfriendly processes. If the hydrogen is to be the true environment-friendly source of energy, the electricity needed for its production must be produced by environment-friendly processes such as collection of energy with solar cells.

There are two types of hydrogen vehicles: vehicles using hydrogen as direct energy source and vehicles using fuel cells. The former use IC engines which have been modified compared to standard petrol engines and which combust hydrogen in the same way the petrol is combusted. However, the most popular hydrogen vehicles nowadays are the ones using fuels cells.

#### 4.1. Propulsion using hydrogen combustion in IC engines

Hydrogen can also be used in conventional petrol engines as its flame spreads quickly from the ignition core throughout the chamber. However, due to smaller energy density of hydrogen compared to petrol, at pressures suitable for cylinder pistons, engine displacement must be two or even three times bigger than of petrol engines (around 4 litres and 8 to 12 cylinders are needed), which is a problem in terms of space for its accommodation. The comparative overview of some characteristics of hydrogen and petrol has been presented in Tab. 2 [20,21].

Table 2. Comparative overview of certain characteristics of hydrogen and petrol in IC engines

Characteristic	Hydrogen	Gasoline	Unit
Minimum ignition energy in air	0.018	0.2 – 0.3	mJ
Flame temperature	2,207	2,307	°C
Autoignition temperature	575 – 580	480 – 550	°C
Flame velocity in air ( $\lambda = 1$ ) at 20 °C and atmospheric pressure	2.37	0.12	m/s
Octane number	> 130	90-98	-
Flammability limits in air	4.1 – 75.6	1.48 – 2.3	% of volume

Since large amounts of hydrogen are required in relation to the engine displacement, hydrogen needs to be much denser than it is possible in its gaseous form. Therefore, it is necessary to use liquid hydrogen cooled down to the temperature of 20 K, as well as special filling stations. Such technologies are already being developed and special tanks for liquid hydrogen have already been designed (with several layers of metal cylinders with appropriate insulation). However, it is also necessary to solve the problems of heat dissipation and hydrogen leakage.

Hydrogen as motor fuel is easier to use in public transportation vehicles. The engine and tank size problem is relatively easy to solve on city buses because of more space, including roof.

Hydrogen propulsion using IC engine can be achieved by modifying existing engine in a certain way: valve thermal treatment, the usage of non-platinum tip spark plugs, higher coil voltage, injectors designed for gas (not liquid) usage, more durable gasket materials, higher temperature engine oils etc. Many manufacturers have experimented with hydrogen engines. Mazda has developed Wankel engine for hydrogen combustion, the Austrian company Alset has developed hybrid hydrogen/petrol system for Aston Martin Rapide S vehicle which participated in 24 Hours Nürburgring race [22] and BMW has developed their own supercar reaching the speed of 301 km/h burning hydrogen [23].

#### 4.2. Propulsion using fuel cells

The increasingly popular technology widespread with hydrogen cars is the fuel cell technology. The fuel cell converts chemical energy into electric energy with the help of chemical reaction of positively-charged ions of hydrogen with oxygen or another oxidation agent. It is important to distinguish fuel cells from batteries because fuel cells need the flow of fuel and oxygen (air) in order to maintain the chemical reaction and produce electricity. This continuity in the production of electricity, as long as the fuel cell is supplied with fuel and oxygen (air), is its advantage.

There are many types of fuel cells [24], but the principle of their operation is essentially the same. Each of them has a cathode, an anode and an electrolyte which enable positively-charged hydrogen ions to flow inside the fuel cell. The cathode and anode have the catalyst which causes the fuel reaction so that it can generate positively-charged ions and electrons. While the hydrogen ions flow through the electrolyte after the reaction, electrons flow from the anode to the cathode through the external circuit, thus producing direct current. Fuel cells are mostly classified by the type of used electrolyte and by the time of the reaction initiation, which can vary from one second to several minutes. Besides electricity, fuel cells produce water and heat, as well as the small amount of nitrogen oxides and other emissions depending on the used fuel.

In theory, fuel cells would function without losses, but that is not the case in real conditions. During their normal function, the major losses of the fuel cell are: activation losses which directly

depend on the degree of the chemical reaction; voltage drop due to the resistance of the medium to the flow of ions and electrons; and concentration losses depending on the reactant concentration and their changes. Theoretical voltage which the fuel cell can achieve is somewhere around 1.2 V. However, due to the energy efficiency of the cell, which ranges from 40% to 60% [25], real operating voltage of the cell is between 0.45 and 0.72 V. Depending on the purpose of the fuel cells, they can be connected in two ways: in series (which produces higher voltages) or in parallel (which produces higher electric currents). For the needs of motor vehicles, fuel cells are arranged in a way in which reacting gases must be uniformly distributed in all cells in order to gain maximum power output.

The type of electrolyte and its chemical composition determine the type of the fuel cell itself. The fuel it uses is also very important, but pure hydrogen is used most commonly. The anode catalyst, which is usually fine platinum powder, initiates the fuel and dissolves it into electrons and ions. Cathode catalyst, which is most often made of nickel, transforms ions into chemical compounds such as water or, rarely, dioxides of other elements. For the needs of hydrogen vehicle propulsion systems, fuel cells with polymer electrolyte membrane (PEM) represent an optimum choice because of its low operating temperature which enables mobility essential for the vehicle.

At this point of hydrogen vehicles development, Toyota has made the greatest progress by presenting the first commercial vehicle model with fuel cells at the end of 2014. Toyota Mirai uses PEM fuel cells – there are 370 of them in the package, arranged in series. One fuel cell is 1.34 mm wide and 102 g heavy, whereas the total weight of all cells in the package is 56 kg. The curb weight of the vehicle is 1,850 kg. Increased fuel-cell output voltage enables reduction of the size of the electric motor, as well as of the number of fuel cells in the package. Hydrogen tank refilling lasts 3 to 5 minutes and the vehicle with full tank can cover almost 500 km. This type of vehicle has two tanks made of plastic reinforced with carbon fibres weighing together 88 kg. Fuel cells, arranged in a three-dimensional grid for better dispersion of oxygen, can have total maximum power output of 114 kW [26]. Current researches are pointed at making the fuel cells more efficient fuel using advanced control strategies [27,28].

## 5. Conclusion

It should be emphasized that almost all forecasts so far, especially the ones from the end of the previous century, have anticipated a significantly greater usage of electric vehicles in first two decades of 21<sup>st</sup> century, but that did not happen. The reasons for this may include the existence of the “fossil fuels lobby”, high prices of today’s electric vehicles and undeveloped infrastructure of charging stations. The real environmental effect of electric vehicles should also be taken into consideration. In countries where electric energy is mostly generated from renewable sources of energy (water, wind, tidal and solar energy), electric vehicles can be considered as vehicles with zero emission. However, in countries like Serbia, where most of the electric energy is generated by burning coal, that is not the case - Here, the emitted amount of carbon dioxide during the production of electric energy needed to power the electric vehicle can be just slightly smaller or in some cases even bigger than the amount that IC engine would emit. There would also be a problem of capacity for production of electric energy if most of the vehicles had electric drive systems.

It is clear that future solutions must overcome many obstacles standing in the way of commercialization of hydrogen as a motor fuel. First of all, it implies the reduction of hydrogen production and transport costs, as well as building of a well-spread network of filling stations. Experts anticipate that, despite the presence of certain models, the mass production of hydrogen vehicles will not start in the following 15 years. However, hydrogen, being the most widespread chemical element, is considered a very promising energy source.

Of all above-mentioned vehicles, the ones with the hybrid drive are most widespread, even though together with electric vehicles they do not reach 1% of the total number of motor vehicles in the world. Still, the number of hybrid vehicles has significantly increased in the last 10 years. What also helps is the fact that future users are stimulated by various incentives. Besides, the use of hybrid vehicles does not have any particular disadvantages such as the undeveloped infrastructure of charging stations (excluding plug-in hybrid vehicles) or a very high purchase price. Unlike electric and hydrogen vehicles, hybrid vehicles cannot be considered as zero exhaust emission vehicles, but the environmental advantage they have over traditional IC engine vehicles must not be disregarded. In that sense, the hybrid drive should be regarded as an acceptable temporary solution which will, with technological

development and solutions to above-mentioned problems, be fully replaced by electric or hydrogen propulsion system.

Several major vehicle producers have announced that, in the following 5 to 10 years, they would completely switch to hybrid and/or electric propulsion systems. However, long-term forecasts on the destiny of IC engines in vehicles have not come true. It turns out that the scientific and technological development is a necessary but not a sufficient condition to solve the problems mentioned in the introduction. What it really takes is environmental awareness in all of us.

## Acknowledgment

This paper presents some of the results obtained through the project supported by Serbian Ministry of Education, Science and Technological Development (TR 35045 - "Scientific-Technological Support to Enhancing the Safety of Special Road and Rail Vehicles").

## References

- [1] Cobb, L., The History and Future of World Energy, *The Quaker Economist*, 7 (2007), pp. 155
- [2] [www.statista.com/statistics/281134/number-of-vehicles-in-useworldwide](http://www.statista.com/statistics/281134/number-of-vehicles-in-useworldwide)
- [3] [www.greencarreports.com/news/1093560\\_1-2-billion-vehicles-onworlds-roads-now-2-billion-by-2035-report](http://www.greencarreports.com/news/1093560_1-2-billion-vehicles-onworlds-roads-now-2-billion-by-2035-report)
- [4] Silva, C.M., *et al.*, EcoGest – Numerical Modelling of the Dynamic Fuel Consumption and Tailpipe Emission of Vehicles Equipped with Spark Ignitions engines, in: *Urban Transport VIII* (Eds. Sucharov, L.J. et al.), WIT Press, Southampton, 2002
- [5] Fast Facts - US Transportation Sector Greenhouse Gas Emissions 1990-2015, US Environmental Protection Agency, 2017
- [6] Greenhouse Gas Emissions from a Typical Passenger Vehicle, US Environmental Protection Agency, 2014
- [7] Carbon Dioxide Levels Rose at Record Pace for 2<sup>nd</sup> Straight Year, National Oceanic and Atmospheric Administration, 2017
- [8] Blagojević, I., Mitić, S., *Vehicles and Environment* (in Serbian), University of Belgrade, Faculty of Mechanical Engineering, Belgrade, 2017.
- [9] Ehsani, M. *et al.*, *Modern Electric, Hybrid Electric, and Fuel Cell Vehicles: Fundamentals, Theory, and Design* (2<sup>nd</sup> ed), CRC Press, Boca Raton, FL, 2009.
- [10] Blagojević, I. *et al.*, Energy Efficiency Improvement by Gear Shifting Optimization, *Thermal Science*, 17 (2013), 1, pp. 91-105
- [11] Blagojević, I., *Fuel Consumption and Saving – Basic Theory and Practical Examples*, University of Belgrade, Faculty of Mechanical Engineering, Belgrade, 2016
- [12] Enang, W., Bannister, C., Modelling and Control of Hybrid Electric Vehicles (A Comprehensive Review), *Renew. Sust. Energ. Rev.*, 74C (2017), pp. 1210–1239
- [13] Sabri, M.F.M., Danapalasingam, K.A., Rahmat, M.F., A Review on Hybrid Electric Vehicles Architecture and Energy Management Strategies, *Renew. Sust. Energ. Rev.*, 53 (2016), pp. 1433-1442
- [14] Reif, K., *et al.*, *Automotive Handbook* (9<sup>th</sup> ed), Robert Bosch GmbH, Stuttgart, 2014
- [15] Safari, M., Battery Electric Vehicles: Looking Behind to Move Forward, *Energ. Policy*, 115 (2018), pp. 54-65
- [16] De Santiago, J. *et al.* Electrical Motor Drivelines in Commercial All Electric Vehicles - A Review, *IEEE T. Veh. Technol.*, 61 (2012), 2, pp. 475-484
- [17] Self Study Program 820233 - Basics of Electric Vehicles - Design and Function, Volkswagen Group of America, 2013
- [18] Larminie, J., Lowry, J., *Electric Vehicle Technology Explained* (2<sup>nd</sup> ed), Wiley, New York City, NY, 2003
- [19] Gordić, M. *et al.*, Electric Vehicle Conversion: Optimisation of Parameters in the Design Process, *Teh. Vjesn.*, 24 (2017), 4, pp. 1213-1219
- [20] Negurescu, N., *et al.*, Performance Comparison between Hydrogen and Gasoline Fuelled Spark Ignition Engine, *Therm. Sci.*, 15 (2011), 4, pp. 1155-1164

- [21] Gupta, B.R., *Hydrogen Fuel Production, Transport and Storage*, CRC Press, Boca Raton, FL, 2008
- [22] [news.cision.com/propel-technology-ltd/r/history-is-made-as-reliability-and-performance-of-unique-hybrid-hydrogen-technology-is-proved-at-the](https://news.cision.com/propel-technology-ltd/r/history-is-made-as-reliability-and-performance-of-unique-hybrid-hydrogen-technology-is-proved-at-the)
- [23] Müller, C. *et al.* Hydrogen Safety: New Challenges Based on BMW Hydrogen 7, *Proceedings*, Second International Conference on Hydrogen Safety, San Sebastian, Spain, 2007
- [24] Chan, C.C., Chau, K.T., *Modern Electric Vehicle Technology*, Oxford University Press, Oxford, 2001
- [25] Welaya, Y.M.A. *et al.*, A Comparison Between Fuel Cells and Other Alternatives for Marine Electric Power Generation, *Int. J. Nav. Arch. Ocean*, 3 (2011), 2, pp. 141-149
- [26] 2016 Mirai Product Information, Toyota Motor Corporation
- [27] Hames, Y., *et al.*, Analysis of the Control Strategies for Fuel Saving in the Hydrogen Fuel Cell Vehicles, *Int. J. Hydrogen Energ.*, in press (2018)
- [28] Ahmadi, S. *et al.*, Improving Fuel Economy and Performance of a Fuel-Cell Hybrid Electric Vehicle (Fuel-Cell, Battery, and Ultra-Capacitor) Using Optimized Energy Management Strategy, *Energ. Convers. Manage.*, 160 (2018), pp. 74-84